

Multi-Output Switch Mode Power Supply S82R (30/50/75-W Models)

Economical, Easy-to-use Multi-Output Power Supply

- 30 W, 50 W, and 75 W, two-channel multi-output power supply.
- Unified depths and mounting dimensions. Three mounting methods, including front mounting.
- ± 12 -V or ± 15 -V output; ideal for operational amplifiers.
- UL and CSA approved.
- RoHS-compliant



Note: Refer to *Safety Precautions* on page 8.



Model Number Structure

Model Number Legend

Note: Not all combinations are possible. Please refer to *List of Models* in *Ordering Information*, below.

S82R-□□□□
1 2 3 4

1. Input Voltage/Configuration

Number	Input voltage	Configuration
0	100 VAC	Open-frame
2	200 VAC	Open-frame
5	100 VAC	Covered
6	200 VAC	Covered

2. Power Rating

Number	Power ratings
3	30 W
5	50 W
7	75 W

3. Number of Outputs

Number	Number of outputs
2	2

4. Output Voltage

Number	Output voltage	
	V ₁	V ₂
1	5 V	12 V
2	5 V	24 V
7	12 V	12 V
8	15 V	15 V

Ordering Information

List of Models

Note: For details on normal stock models, contact your nearest OMRON representative.

Type	Capacity	Output voltage/current		Model	
		V ₁	V ₂	100 VAC input type	200 VAC input type
Open-frame type	30 W	5V, 2A	12V, 2A	S82R-0321	S82R-2321
		5V, 2A	24V, 1A	S82R-0322	S82R-2322
	30 W	12V, 1.7A	12V, 0.8A	S82R-0327	S82R-2327
		15V, 1A	15V, 1A	S82R-0328	S82R-2328
	50 W	5V, 3A	12V, 3A	S82R-0521	S82R-2521
		5V, 2A	24V, 2A	S82R-0522	S82R-2522
	50 W	12V, 3A	12V, 1.2A	S82R-0527	S82R-2527
		15V, 1.7A	15V, 1.7A	S82R-0528	S82R-2528
75 W	5V, 5A	24V, 2A	S82R-0722	S82R-2722	
	Covered type	30 W	5V, 2A	12V, 2A	S82R-5321
5V, 2A			24V, 1A	S82R-5322	S82R-6322
30 W		12V, 1.7A	12V, 0.8A	S82R-5327	S82R-6327
		15V, 1A	15V, 1A	S82R-5328	S82R-6328
50 W		5V, 3A	12V, 3A	S82R-5521	S82R-6521
		5V, 2A	24V, 2A	S82R-5522	S82R-6522
50 W		12V, 3A	12V, 1.2A	S82R-5527	S82R-6527
		15V, 1.7A	15V, 1.7A	S82R-5528	S82R-6528
75 W	5V, 5A	24V, 2A	S82R-5722	S82R-6722	

Specifications

■ Characteristics

Input		Power rating	100 V input			200 V input		
			30 W	50 W	75 W	30 W	50 W	75 W
Efficiency (typ.)			68% min. (depending on model)					
Input	Voltage (See note 1.)	AC	85 to 132 V			170 to 264 V		
		DC	110 to 170 V (See note 2.)			Not available		
	Frequency (See note 1.)	50/60 Hz (47 to 450 Hz)						
	Current (See note 3.)	1.1 A max.	1.4 A max.	2 A max.	0.7 A max.	0.8 A max.	1.1 A max.	
	Leakage current (See note 3.)	0.5 mA max.			1 mA max.			
	Inrush current (See note 3.)	30 A max. (for a cold start at 25°C)			60 A max. (for a cold start at 25°C)			
	Noise filter	Yes						
Output	Voltage accuracy	V ₁ : 3.5% max. V ₂ : 5% max. (with input, load, and temperature within permissible fluctuation ranges)						
	Voltage adjustment range (See note 4.)	Fixed except for 5-V output which can be adjusted by ±5% (with V. ADJ)						
	Ripple (See note 3.)	2% (p-p) max.						
	Input variation influence	0.4% max. (at 85 to 132 V input, 100% load)			0.4% max. (at 170 to 264 V input, 100% load)			
	Load variation influence	V ₁ : 0.8% max. (at rated input, 10% to 100% load) V ₂ : 2% max.						
	Temperature variation influence	0.05%/°C max. (at rated input/output)						
	Startup time	200 ms max. (Up to 90% of output voltage at rated input and output)						
	Hold up time (See note 3.)	20 ms min.						
Ancillary function	Overload protection (See note 5.)	105% min. of rated current, voltage drop, automatic reset						
	Overvoltage protection	No						
Others	Operating temperature	Refer to the derating curve in <i>Engineering Data</i> (with no icing or condensation).						
	Storage temperature	-25°C to 65°C						
	Operating humidity	25% to 85% (storage humidity: 20% to 90%)						
	Dielectric strength	2.0 kVAC, 50/60 Hz, for 1 minute (between input terminals and output terminals/PE terminal)						
	Insulation resistance	100 MΩ min. (between output terminals and input terminals/PE terminal at 500 VDC)						
	Vibration resistance	10 to 55 Hz, 0.75 mm single amplitude for 2 hours each in X, Y, and Z directions						
	Shock resistance	294 m/s ² , 3 times each in ±X, ±Y, ±Z directions						
	Output indicator	V1 output indicator only (color: red)						
	Approved standards	UL	UL1012					
		CSA	E.B.1402C					
Weight (See note 6.)	400 g max.	500 g max.	550 g max.	400 g max.	500 g max.	550 g max.		

Note: 1. Do not use an inverter output for the Power Supply. Inverters with an output frequency of 50/60 Hz are available, but the rise in the internal temperature of the Power Supply may result in ignition or burning.

2. These Power Supplies do not comply with safety standards if a DC power supply is used.
3. Defined with a 100% load at the rated input voltage (100 or 200 VAC).
4. If the output voltage adjuster (V. ADJ) is turned, the voltage will increase by more than 5% of the voltage adjustment range. When adjusting the output voltage, confirm the actual output voltage from the Power Supply and be sure that the load is not damaged.
5. Refer to *Overload Protection* on page 4 for details.
6. Weights are given for the covered type.

Connections

Block Diagrams

S82R-□□21
S82R-□□22

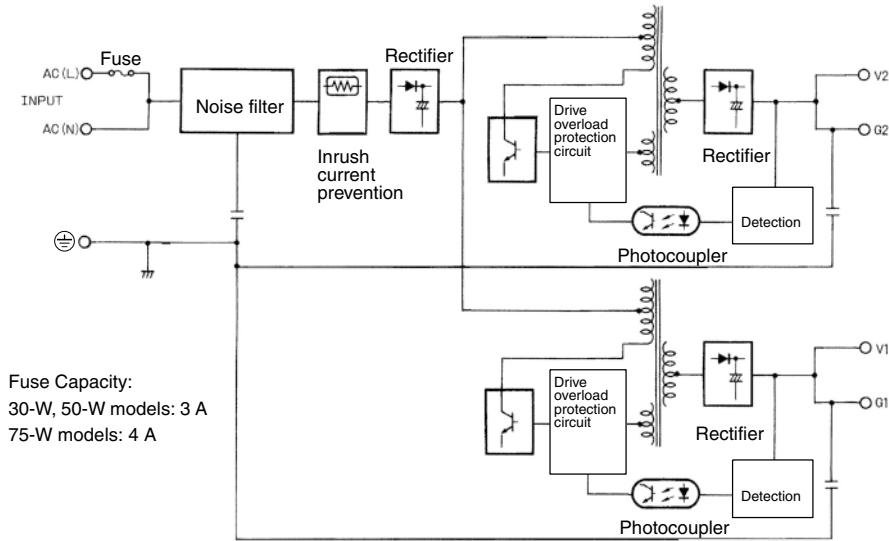

S82R-□□27
S82R-□□28

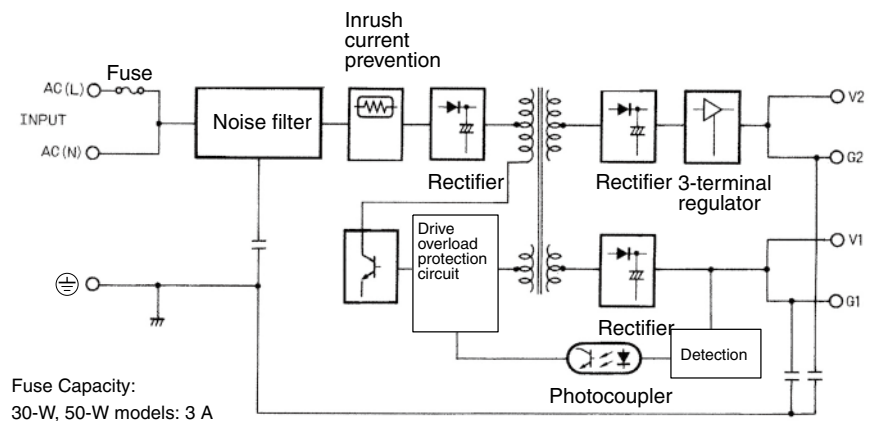

Construction and Nomenclature

Nomenclature

S82R-□□21
S82R-□□22

S82R-□□27
S82R-□□28

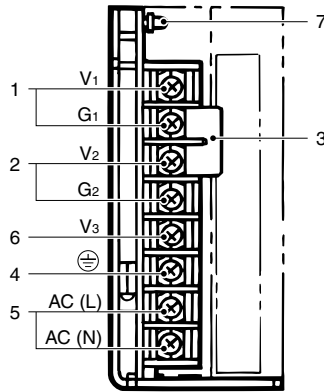
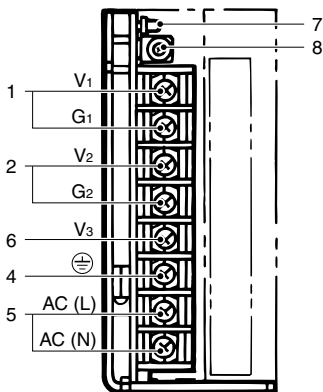

1. V₁ (+), G₁ (-) } DC output terminals: Connect load lines.
 2. V₂ (+), G₂ (-) }
 3. Short bar: Provided to make + outputs. Without it V₁ and V₂ outputs can be used as independent outputs. (Supplied only for S82R-□□27 and S82R-□□28 as an accessory.)
 4. Protective Earthing terminal (⊕): This terminal is short circuited to the frame and must be connected to a ground line.
 5. Input terminal: Connect the input lines to these terminals
- Note:** A fuse is located on the AC(L) side. It is NOT user replaceable.
6. V₃ terminal: Vacant terminal
 7. Output indicator: Lights while V₁ DC voltage is being output.
 8. Output voltage adjuster (V.ADJ): Adjusts the output voltage (provided only for 5-V output type). (S82R-□□21 and S82R-□□22)

Engineering Data

Derating Curve (Standard Installation)

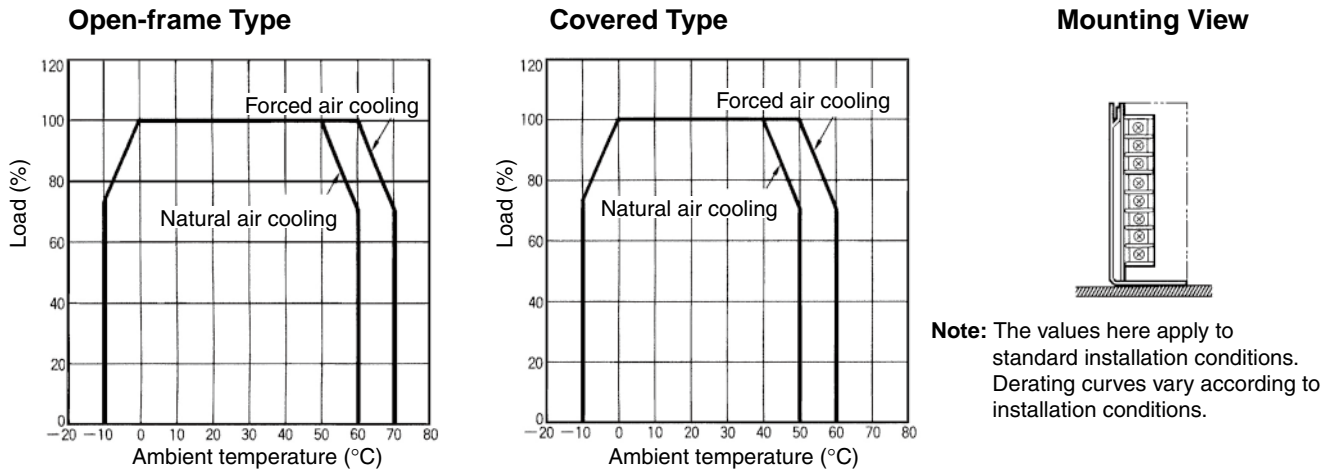

Overload Protection

This function protects the load and the Power Supply from possible damage by overcurrent. Overload detection and reset are as shown below.

S82R-□□21 and □□22

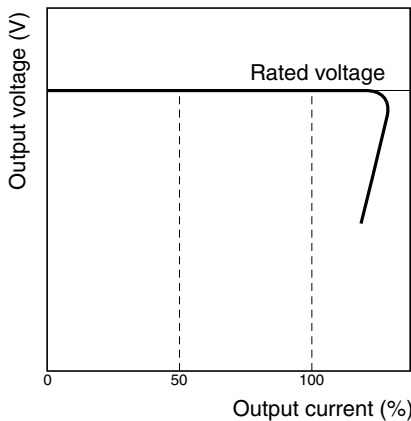

The values shown in the above diagram are for reference only.

Note: Internal parts may occasionally deteriorate or be damaged if a short-circuited or other overcurrent state continues during operation.

Output	Operation	Detection	Reset
V ₁	Voltage drop	105% of rated load current or higher	Automatically reset by overload reset function.

Note: V₁ and V₂ are independent, and they are detected (output shut OFF) and reset separately.

S82R-□□27 and □□28

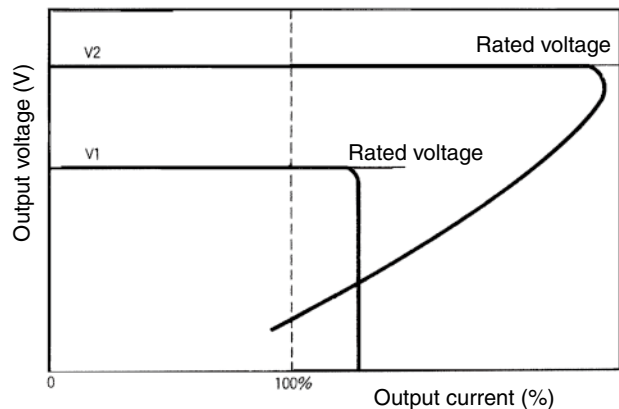

The values shown in the above diagram are for reference only.

Output	Operation	Detection	Reset
V ₁	Voltage drop	105% of rated load current or higher	Automatically reset by overload reset function.
V ₂ , V ₃	Short-circuit protection	---	Automatically reset by overload reset function.

- Note:**
- When an overload is detected for V₁, both outputs (V₁ and V₂) are shut OFF. Both outputs are reset automatically. Overload detection for the V₁ output uses the sum of the output voltages of the V₁ and V₂ outputs. Overload detection thus depends on the output current (output power) of the V₂ output.
 - V₂ is independent, and it is detected (output shut OFF) and reset separately.

■ Current, Startup Time, Output Hold Time

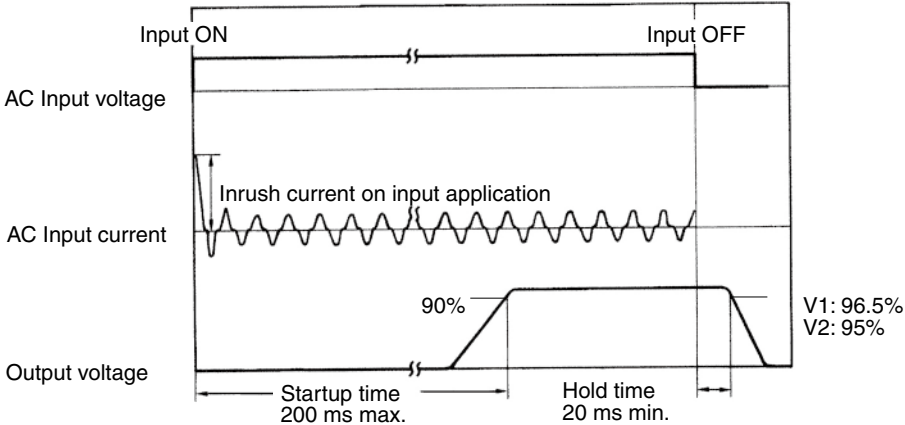

Dimensions

Note: All units are in millimeters unless otherwise specified.

S82R-□3□□ (30W)

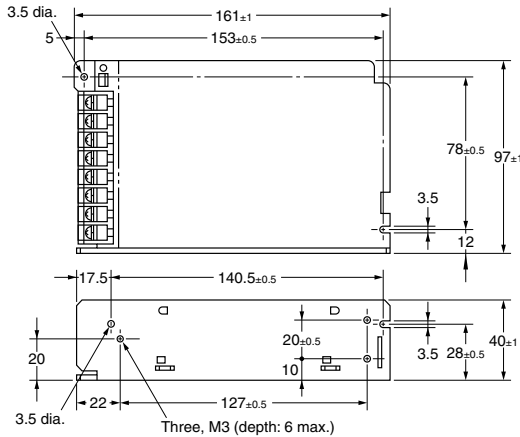
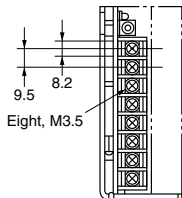
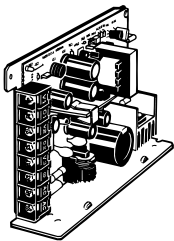

Mounting Holes

Side View

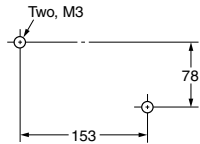

Bottom View

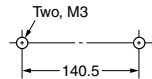

S82R-□5□□ (50W)

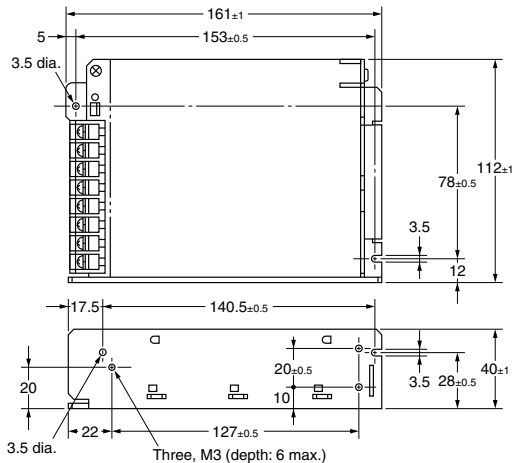
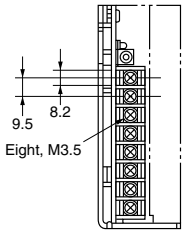
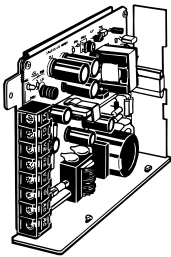

Mounting Holes

Side View

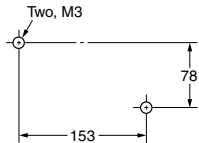

Bottom View

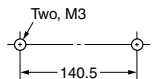

S82R-□7□□ (75W)

Mounting Holes

Side View

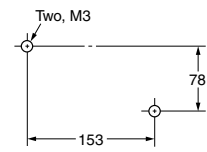

Bottom View

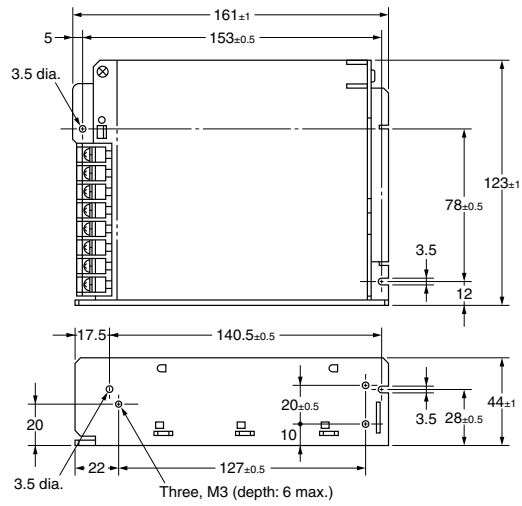
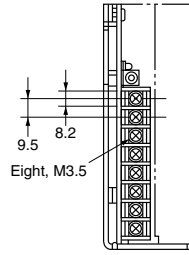
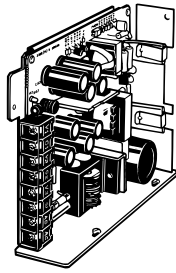
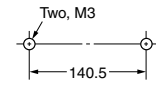

Installation

■ Front Mounting Bracket

Note: The Mounting Bracket is supplied with the Power Supply.

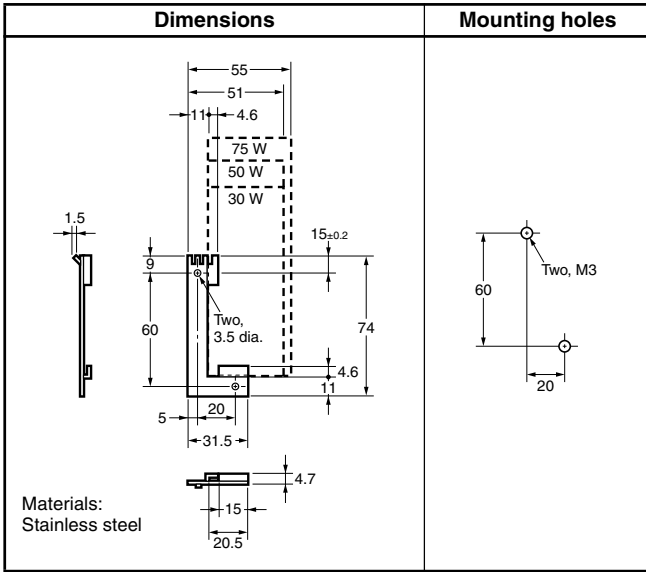

Front Mounting

Attach the enclosed Mounting Bracket temporarily to the mounting surface, hook the rectangular holes on the Power Supply (a) on the hooks on the Bracket (b), and then tighten the two mounting screws.

Note: The mounting screws are not included.

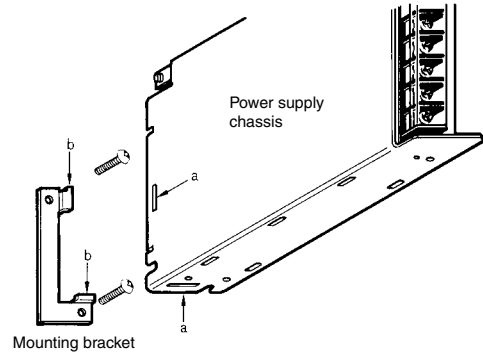

■ DIN Rail Mounting Bracket (Order Separately)

To mount the Power Supply to DIN Rail, use the DIN Rail Mounting Bracket.

S82Y-05N

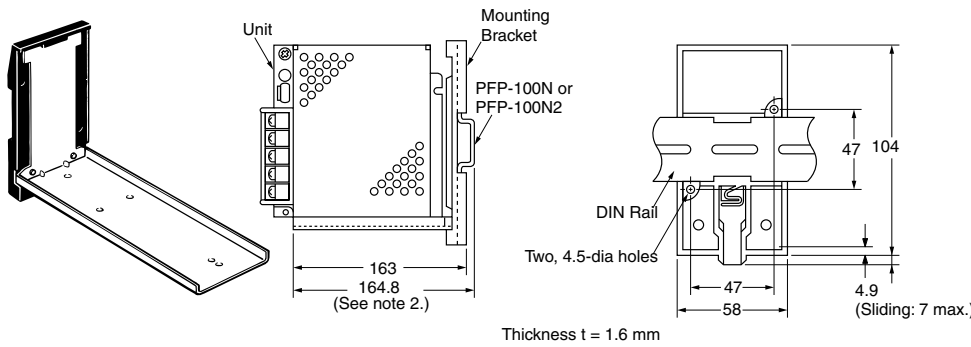

- Note:** 1. All units are in millimeters unless otherwise indicated.
2. Add 10.5 mm to length in the diagram if the PFP-100N2 is used.

■ DIN Rail (Order Separately)

Mounting Rail (Material: Aluminum)



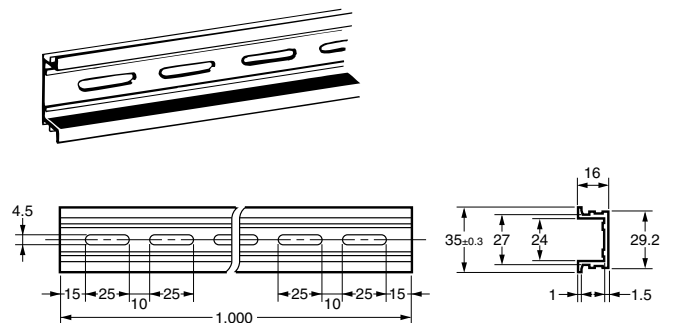
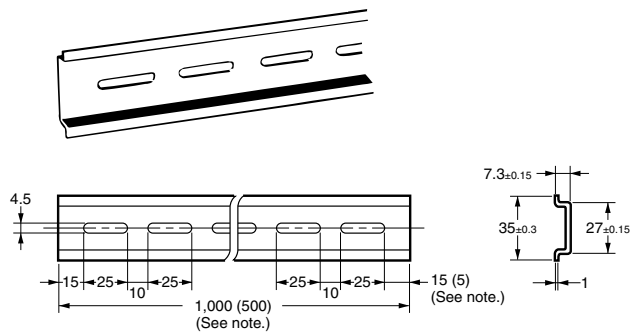

PFP-100N
PFP-50N

PFP-100N2



Note: The values shown in parentheses are for the PFP-50N.

Safety Precautions

⚠ CAUTION	
Minor electric shock, fire, or Product failure may occasionally occur. Do not disassemble, modify, or repair the Product or touch the interior of the Product.	
Minor burns may occasionally occur. Do not touch the Product while power is being supplied or immediately after power is turned OFF.	
Fire may occasionally occur. Tighten terminal screws to the specified torque 0.74 N·m (M3.5).	
Minor injury due to electric shock may occasionally occur. Do not touch the terminals while power is being supplied.	
Minor electric shock, fire, or Product failure may occasionally occur. Do not allow any pieces of metal or conductors or any clippings or cuttings resulting from installation work to enter the Product.	

■ Precautions for Safe Use

Mounting

Install the power supply so that heat is effectively dissipated, to extend the life expectancy and improve the reliability of the power supply.

Install the power supply so that air convection takes place around the power supply as the power supply is designed for natural convection. Provide a distance of at least 20 mm between the power supplies.

When installing two or more power supplies side-by-side, note the following points.

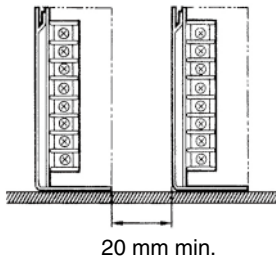

Provide a distance of at least 20 mm between the power supplies. Forced air cooling is strongly recommended.

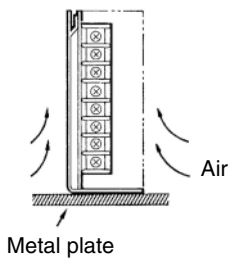

Mounting Method

The Power Supply can be mounted in three different mounting styles, as follows:

- (A) Side mounting
 - (B) Bottom mounting
 - (C) Front mounting
- For details, refer to *Front Mounting Bracket* on page 7.

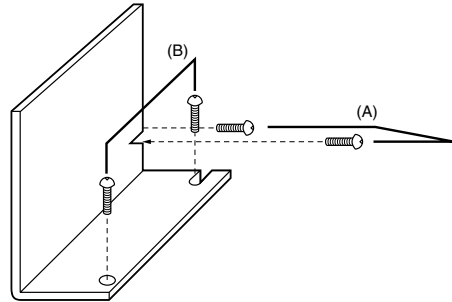

■ Serial Operation

The V_1 output and V_2 output cannot be operated in series.

The V_1 or V_2 output and other power supplies cannot be operated in series.

Incorrect

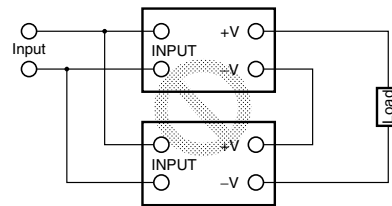

■ Parallel Operation

The V_1 output and V_2 output cannot be operated in parallel.

Furthermore, the V_1 or V_2 output and other power supplies cannot be operated in parallel.

Incorrect

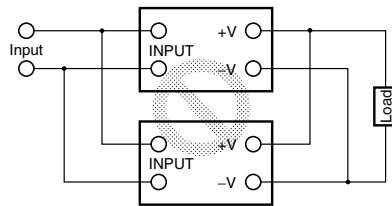

■ Generating Output Voltages (\pm)

(S82R-□□27 and S82R-□□28)

\pm outputs can be made with V_1 and V_2 outputs by attaching the supplied short bar.

Correct

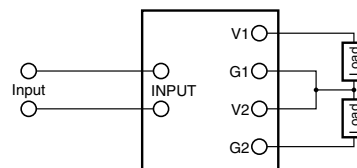

■ Output Voltage Adjustment

(S82R-□□21 and S82R-□□22)

Only the 5-V output can be adjusted. (Other outputs are fixed.)

The output voltage is factory set within ±1% of the rated voltage.

It can be adjusted to a desired level within ±5% of the rated output voltage by using the output voltage adjuster (V. ADJ).

Note: Although it is possible to adjust the output voltage in a wider range than ±5%, do not adjust the voltage to a level exceeding or falling below the ±5% range; otherwise, the output power may exceed the rated capacity.

■ Minimum Output Current

The minimum output current is restricted by the output voltage and control method.

Model	V ₁ output	V ₂ output
S82R-□□21 S82R-□□22	No limitation	No limitation
S82R-□□27 S82R-□□28	With limitation (See note.)	No limitation

Note: S82R-□□27 and S82R-□□28 control V₁ output directly and V₂ indirectly. Therefore, if V₁ output current falls to 10% or less of rated output current, V₂ output voltage may drop.

ALL DIMENSIONS SHOWN ARE IN MILLIMETERS.
To convert millimeters into inches, multiply by 0.03937. To convert grams into ounces, multiply by 0.03527.

In the interest of product improvement, specifications are subject to change without notice.

Read and Understand This Catalog

Please read and understand this catalog before purchasing the products. Please consult your OMRON representative if you have any questions or comments.

Warranty and Limitations of Liability

WARRANTY

OMRON's exclusive warranty is that the products are free from defects in materials and workmanship for a period of one year (or other period if specified) from date of sale by OMRON.

OMRON MAKES NO WARRANTY OR REPRESENTATION, EXPRESS OR IMPLIED, REGARDING NON-INFRINGEMENT, MERCHANTABILITY, OR FITNESS FOR PARTICULAR PURPOSE OF THE PRODUCTS. ANY BUYER OR USER ACKNOWLEDGES THAT THE BUYER OR USER ALONE HAS DETERMINED THAT THE PRODUCTS WILL SUITABLY MEET THE REQUIREMENTS OF THEIR INTENDED USE. OMRON DISCLAIMS ALL OTHER WARRANTIES, EXPRESS OR IMPLIED.

LIMITATIONS OF LIABILITY

OMRON SHALL NOT BE RESPONSIBLE FOR SPECIAL, INDIRECT, OR CONSEQUENTIAL DAMAGES, LOSS OF PROFITS, OR COMMERCIAL LOSS IN ANY WAY CONNECTED WITH THE PRODUCTS, WHETHER SUCH CLAIM IS BASED ON CONTRACT, WARRANTY, NEGLIGENCE, OR STRICT LIABILITY.

In no event shall responsibility of OMRON for any act exceed the individual price of the product on which liability is asserted.

IN NO EVENT SHALL OMRON BE RESPONSIBLE FOR WARRANTY, REPAIR, OR OTHER CLAIMS REGARDING THE PRODUCTS UNLESS OMRON'S ANALYSIS CONFIRMS THAT THE PRODUCTS WERE PROPERLY HANDLED, STORED, INSTALLED, AND MAINTAINED AND NOT SUBJECT TO CONTAMINATION, ABUSE, MISUSE, OR INAPPROPRIATE MODIFICATION OR REPAIR.

Application Considerations

SUITABILITY FOR USE

OMRON shall not be responsible for conformity with any standards, codes, or regulations that apply to the combination of products in the customer's application or use of the product.

At the customer's request, OMRON will provide applicable third party certification documents identifying ratings and limitations of use that apply to the products. This information by itself is not sufficient for a complete determination of the suitability of the products in combination with the end product, machine, system, or other application or use.

The following are some examples of applications for which particular attention must be given. This is not intended to be an exhaustive list of all possible uses of the products, nor is it intended to imply that the uses listed may be suitable for the products:

- Outdoor use, uses involving potential chemical contamination or electrical interference, or conditions or uses not described in this catalog.
- Nuclear energy control systems, combustion systems, railroad systems, aviation systems, medical equipment, amusement machines, vehicles, safety equipment, and installations subject to separate industry or government regulations.
- Systems, machines, and equipment that could present a risk to life or property.

Please know and observe all prohibitions of use applicable to the products.

NEVER USE THE PRODUCTS FOR AN APPLICATION INVOLVING SERIOUS RISK TO LIFE OR PROPERTY WITHOUT ENSURING THAT THE SYSTEM AS A WHOLE HAS BEEN DESIGNED TO ADDRESS THE RISKS, AND THAT THE OMRON PRODUCT IS PROPERLY RATED AND INSTALLED FOR THE INTENDED USE WITHIN THE OVERALL EQUIPMENT OR SYSTEM.

Disclaimers

CHANGE IN SPECIFICATIONS

Product specifications and accessories may be changed at any time based on improvements and other reasons.

It is our practice to change model numbers when published ratings or features are changed, or when significant construction changes are made. However, some specifications of the product may be changed without any notice. When in doubt, special model numbers may be assigned to fix or establish key specifications for your application on your request. Please consult with your OMRON representative at any time to confirm actual specifications of purchased product.

DIMENSIONS AND WEIGHTS

Dimensions and weights are nominal and are not to be used for manufacturing purposes, even when tolerances are shown.

ERRORS AND OMISSIONS

The information in this catalog has been carefully checked and is believed to be accurate; however, no responsibility is assumed for clerical, typographical, or proofreading errors, or omissions.

PERFORMANCE DATA

Performance data given in this catalog is provided as a guide for the user in determining suitability and does not constitute a warranty. It may represent the result of OMRON's test conditions, and the users must correlate it to actual application requirements. Actual performance is subject to the OMRON Warranty and Limitations of Liability.

PROGRAMMABLE PRODUCTS

OMRON shall not be responsible for the user's programming of a programmable product, or any consequence thereof.

COPYRIGHT AND COPY PERMISSION

This catalog shall not be copied for sales or promotions without permission.

This catalog is protected by copyright and is intended solely for use in conjunction with the product. Please notify us before copying or reproducing this catalog in any manner, for any other purpose. If copying or transmitting this catalog to another, please copy or transmit it in its entirety.