

Switch Mode Power Supply S8JX (35/50/100/150-W Models)

Compact Power Supply Compliant with Global Standards

- Output voltages of 5 V, 12 V, and 24 V are available for between 35 to 150 W capacity (100 W, 150 W: 24-V models only)
- Supports DIN Rail mounting.
- Safety standards:
UL 508/60950-1, EN 60950-1
CSA C22.2 No. 60950-1

Terminal Block: Based on Finger Protection (According to VDE0106/P100)

Note: Refer to *Precautions for Safe Use* on page 8.

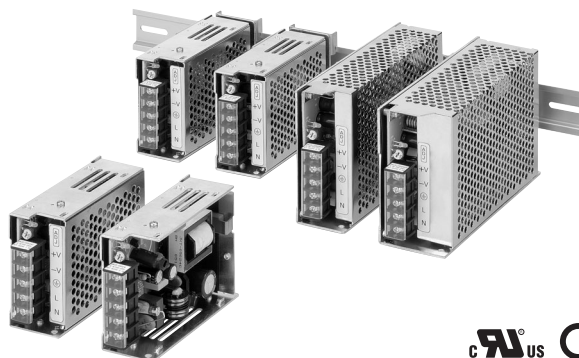

Model Number Structure

Model Number Legend

Not all model number combinations are available. (For details on possible combinations, refer to *Ordering Information*.)

S8JX-□□□□□□□□
1 2 3 4

1. Power Ratings

035: 35 W
050: 50 W
100: 100 W
150: 150 W

2. Output voltage

05: 5 V
12: 12 V
24: 24 V

3. Configuration

None: Open-frame type
C: Covered type

4. Configuration

None: Front-mounting type
D: DIN Rail mounting bracket type

Ordering Information

Configuration	Power ratings	Input voltage	Output voltage	Output current	Front-mounting type	DIN Rail mounting bracket type	
Open-frame type	35 W	200 to 240 VAC	5V	7 A	S8JX-03505	S8JX-03505D	
			12V	2.9 A	S8JX-03512	S8JX-03512D	
			24V	1.5 A	S8JX-03524	S8JX-03524D	
	50 W		5V	10 A	S8JX-05005	S8JX-05005D	
			12V	4.2 A	S8JX-05012	S8JX-05012D	
			24V	2.1 A	S8JX-05024	S8JX-05024D	
	100 W		24V	4.2 A	S8JX-10024	S8JX-10024D	
			150 W	24V	6.5 A	S8JX-15024	S8JX-15024D
				Covered Type	35 W	5V	7 A
12V	2.9 A	S8JX-03512C				S8JX-03512CD	
24V	1.5 A	S8JX-03524C	S8JX-03524CD				
50 W	5V	10 A	S8JX-05005C		S8JX-05005CD		
	12V	4.2 A	S8JX-05012C		S8JX-05012CD		
	24V	2.1 A	S8JX-05024C		S8JX-05024CD		
100 W	24V	4.2 A	S8JX-10024C		S8JX-10024CD		
	150 W	24V	6.5 A		S8JX-15024C	S8JX-15024CD	

Specifications

■ Ratings/Characteristics

Item		Power ratings	35 W	50 W	100 W	150 W
Efficiency (typical)	5-V models		67% min.	73% min.	---	---
	12-V models		76% min.	78% min.	---	---
	24-V models		76% min.	78% min.	78% min.	81% min.
Input	Voltage (See note 1.)	200 to 240 VAC (170 to 264 VAC)				
	Frequency (See note 1.)	50/60 Hz (47 to 450 Hz)				
	Current	200 V input	0.6 A max.	0.8 A max.	1.6 A max.	2.5 A max.
	Power factor	---				
	Harmonic current emissions	---				
	Leakage current	200 V input	1.0 mA max.			
	Inrush current (See note1.)	200 V input	50 A max. (for a cold start at 25°C)			
Output	Voltage adjustment range (See note 3.)	-10% to 15% (with V. ADJ) (guaranteed)				
	Ripple	250 mV (p-p) max. (5 V), 240 mV (p-p) max. (12 V), 480 mV (p-p) max. (24 V) (at rated input/output voltage)				
	Input variation influence	0.5% max.				
	Load variation influence (rated input voltage)	1.5% max.				
	Temperature variation influence	0.05%/°C max.				
	Start up time (See note2.)	1500 ms max. (at rated input/output voltage)				
	Hold time (See note 2.)	20 ms min. (at rated input/output voltage)				
Additional functions	Overload protection (See note 2.)	105% to 180% of rated load current, voltage drop, intermittent, automatic reset			105% to 160% of rated load current, voltage drop, intermittent, automatic reset	
	Overvoltage protection	No				
	Undervoltage alarm indication	No				
	Undervoltage alarm output terminals	No				
	Parallel operation	No				
Series operation	No					
Other	Operating ambient temperature	Refer to the derating curve in Engineering Data. (with no icing or condensation)				
	Storage temperature	-25 to 65°C				
	Operating ambient humidity	25% to 85% (Storage humidity: 25% to 90%)				
	Dielectric strength	3.0 kVAC for 1 min. (between all inputs and outputs; detection current: 20 mA) 2.0 kVAC for 1 min. (between all inputs and PE terminals; detection current: 20 mA) 1.0 kVAC for 1 min. (between all outputs and PE terminals; detection current: 20 mA)				
	Insulation resistance	100 MΩ min. (between all outputs and all inputs/PE terminals) at 500 VDC				
	Vibration resistance	10 to 55 Hz, 0.375-mm single amplitude for 2h each in X, Y, and Z directions				
	Shock resistance	150m/s ² , 3 times each in ±X, ±Y, ±Z directions				
	Output indicator	Yes (color: Green)				
	EMI	Conducted Emissions	Conforms to EN 61204-3 EN 55011 Class A			
		Radiated Emissions	Conforms to EN 61204-3 EN 55011 Class A			
	EMS	Conforms to EN 61204-3 High Severity Levels				
	Approved standards	UL 508/60950-1, EN 60950-1 cUL: CSA C22.2 No. 60950-1 SELV (EN 60950-1) According to VDE 0106/P100				
	Weight		420 g max.	440 g max.	600 g max.	720 g max.

- Note:**
- Do not use the Inverter output for the Power Supply. Inverters with an output frequency of 50/60 Hz are available, but the rise in the internal temperature of the Power Supply may result in ignition or burning.
 - Refer to the *Engineering Data* section on page 4 for details.
 - If the V. ADJ adjuster is turned, the voltage will increase by more than +15% of the voltage adjustment range. When adjusting the output voltage, confirm the actual output voltage from the Power Supply and be sure that load is not damaged.

Connections

Block Diagrams

S8JX-035 (35 W)
S8JX-050 (50 W)

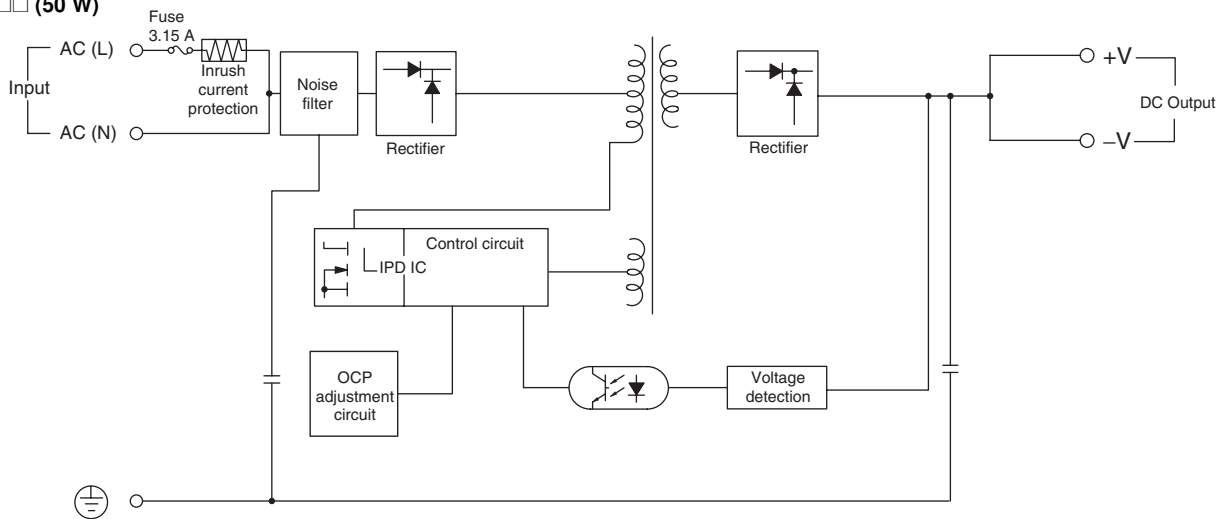

S8JX-100 (100 W)
S8JX-150 (150 W)

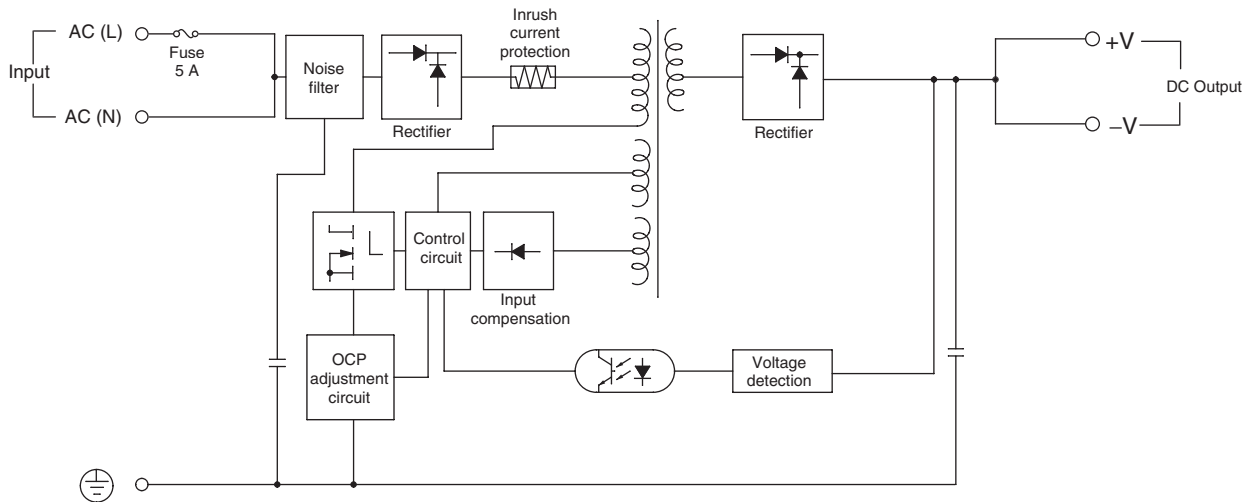

Construction and Nomenclature

Nomenclature

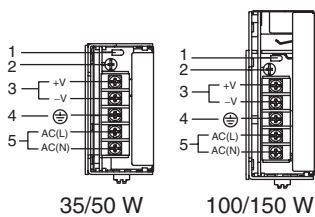

No.	Name	Function
1	Output indicator (DC ON: Green)	Lights while a direct current (DC) output is ON.
2	Output voltage adjuster (V. ADJ)	Use to adjust the voltage. It is possible to increase or decrease the output voltage by -10% to 15%
3	DC output terminals (-V). (+V)	Connect the load lines to these terminals.
4	Protective Earth terminal (PE)	Connect the ground line to these terminals. (See note 1.)
5	AC input terminals (L). (N)	Connect the input lines to these terminals. (See note 2.)

Note: 1. This is the protective earth terminal specified in the safety standards. Always ground this terminal.

2. The fuse is located on the (L) side. It is NOT user-replaceable.

Engineering Data

Derating Curve

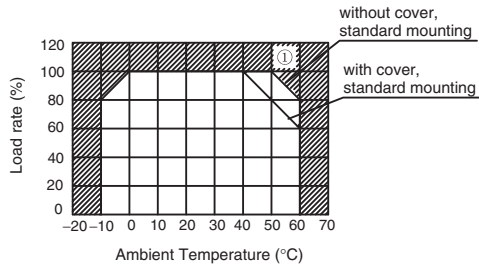

- Note:**
- Internal parts may occasionally deteriorate or be damaged. Do not use the Power Supply in areas outside the derating curve (i.e., the area shown by shading ① in the above graph).
 - If there is a derating problem, use forced air-cooling.
 - The peripheral temperature is specified at the place 75 mm downward from the main body of Power Supply unit.

Mounting

Standard Mounting
(Front-mounting type)

Standard Mounting
(DIN Rail mounting bracket type)

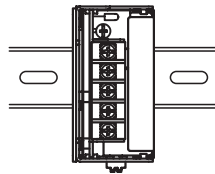
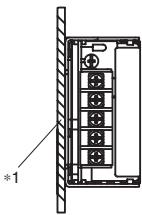

- Note:**
- Improper mounting will interfere with heat dissipation and may occasionally result in deterioration or damage of internal parts. Use the standard mounting method only.
 - When mounting the Power Supply, mounting it to a metal plate (*1) is recommended.
 - Install the Power Supply so that the air flow circulates around the Power Supply, as the Power Supply is designed to radiate heat by means of natural air flow.

Overload Protection

The Power Supply is provided with an overload protection function that protects the power supply from possible damage by overcurrent. When the output current rises above 105% min. of the rated current, the protection function is triggered, decreasing the output voltage. When the output current falls within the rated range, the overload protection function is automatically cleared.

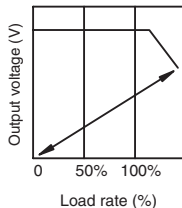

The values shown in the above diagram are for reference only.

- Note:**
- Internal parts may occasionally deteriorate or be damaged if a short-circuited or overcurrent state continues during operation. Remove the cause of the short-circuited or overcurrent state as quickly as possible.
 - Internal parts may possibly deteriorate or be damaged if the Power Supply is used for applications with frequent inrush current or overloading at the load end. Do not use the Power Supply for such applications.

Inrush Current, Start Up Time, Output Hold Time

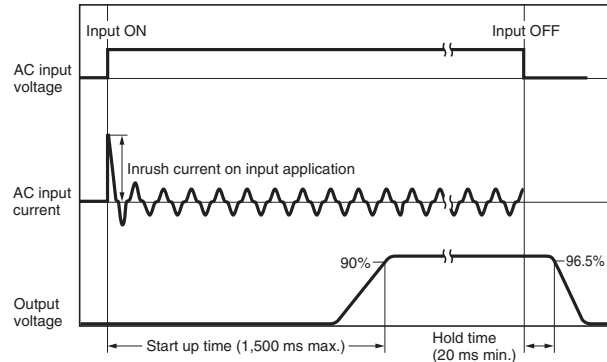

Reference Values

Item	Value	Definition
Reliability	500,000 hrs. min.	MTBF stands for Mean Time Between Failures, which is calculated according to the probability of accidental device failures, and indicates reliability of devices. Therefore, it does not necessarily represent a life of the Product.
Life expectancy	5 yrs. min.	The life expectancy indicates average operating hours under the ambient temperature of 40°C and a load rate of 50%. Normally this is determined by the life expectancy of the built-in aluminum electrolytic capacitor.

Dimensions

Note: All units are in millimeters unless otherwise indicated.

Open-frame type

S8JX-035□□/S8JX-035□□D (35 W)
S8JX-050□□/S8JX-050□□D (50 W)

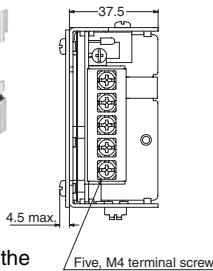
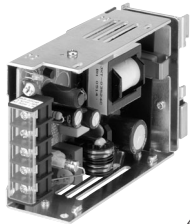

Note: The image is the S8JX-03524D.

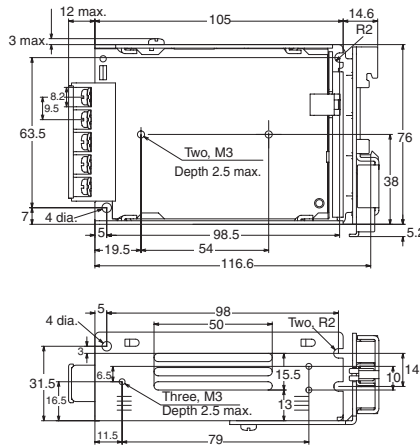

Panel mounting holes dimensions

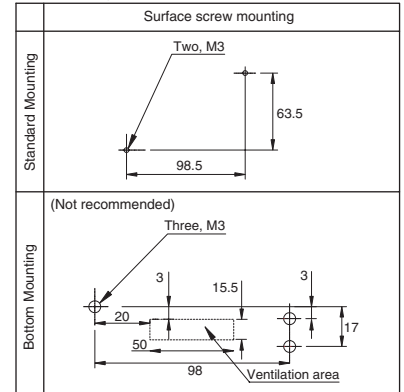

S8JX-10024/S8JX-10024D (100 W)

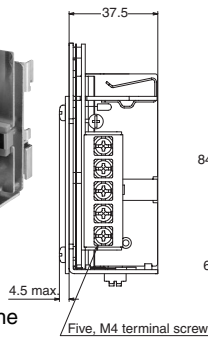
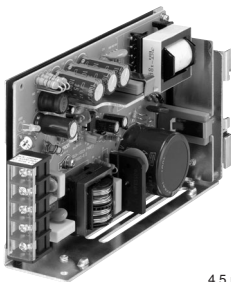

Note: The image is the S8JX-10024D.

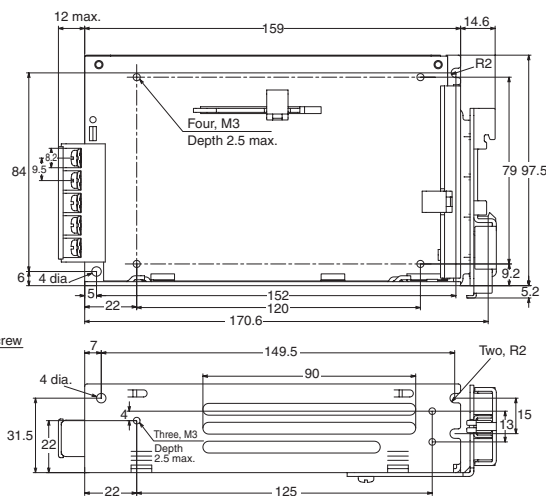

Panel mounting holes dimensions

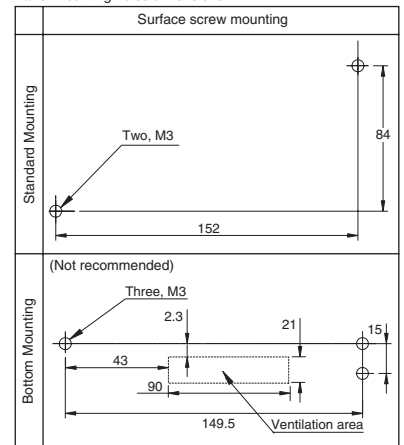

S8JX-15024/S8JX-15024D (150 W)

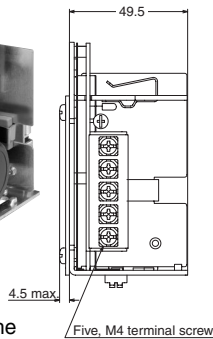
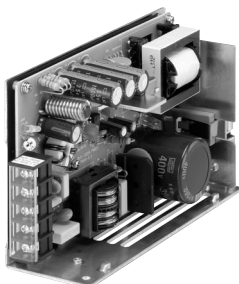

Note: The image is the S8JX-15024D.

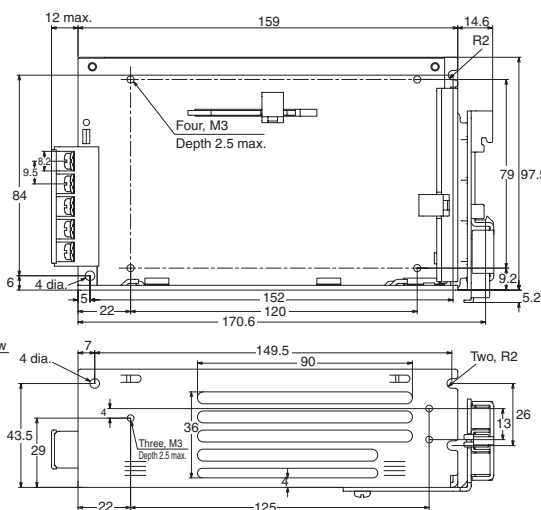

Panel mounting holes dimensions

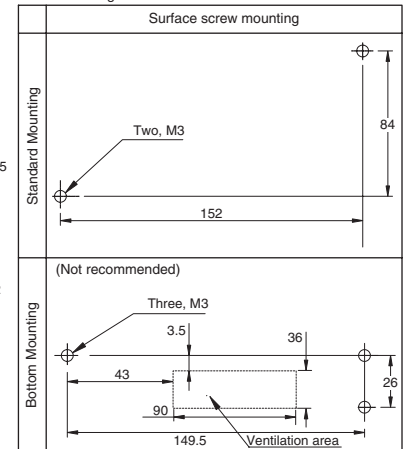

■ Covered type

S8JX-035□□C/S8JX-035□□CD (35 W)
 S8JX-050□□C/S8JX-050□□CD (50 W)

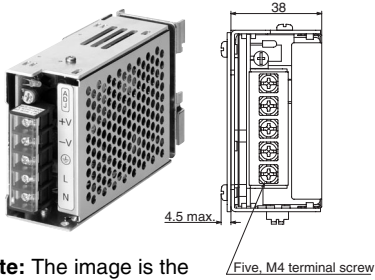

Note: The image is the S8JX-03524CD.

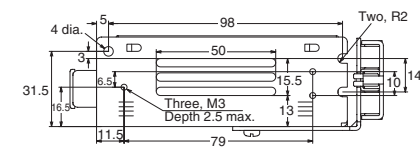
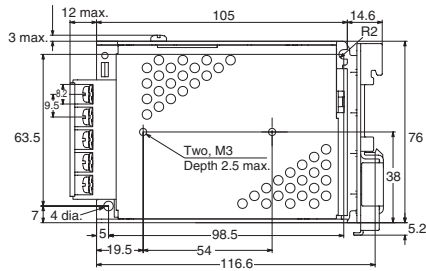

Panel mounting holes dimensions

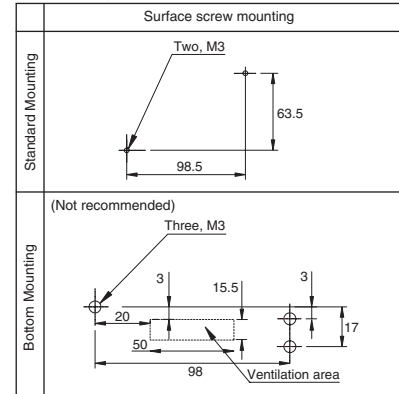

S8JX-10024C/S8JX-10024CD (100 W)

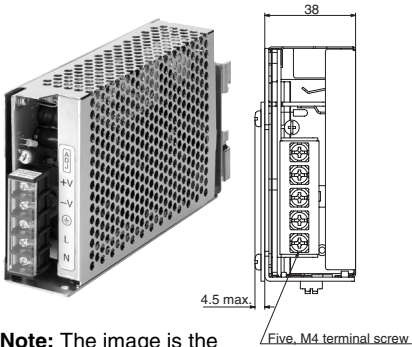

Note: The image is the S8JX-10024CD.

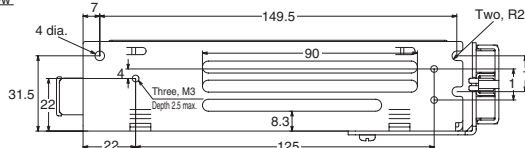
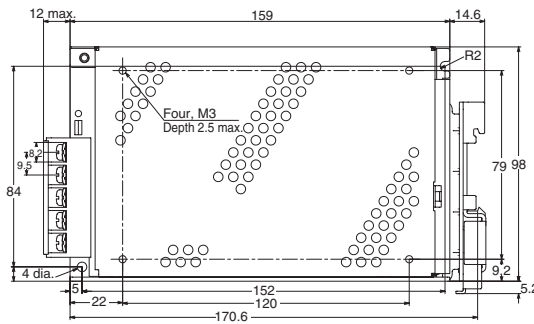

Panel mounting holes dimensions

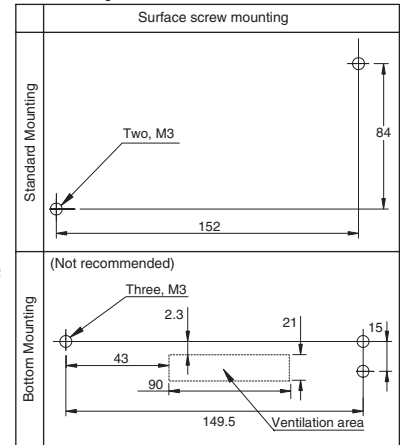

S8JX-15024C/S8JX-15024CD (150 W)

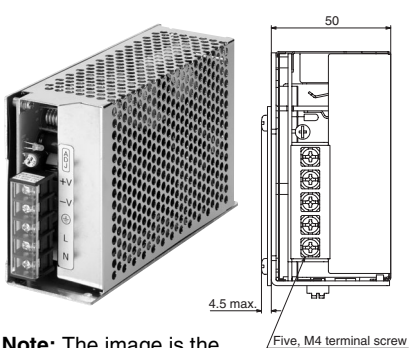

Note: The image is the S8JX-15024CD.

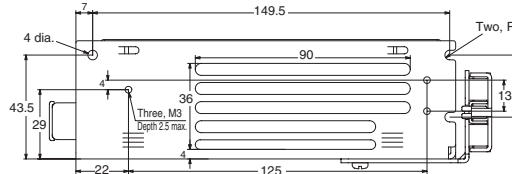
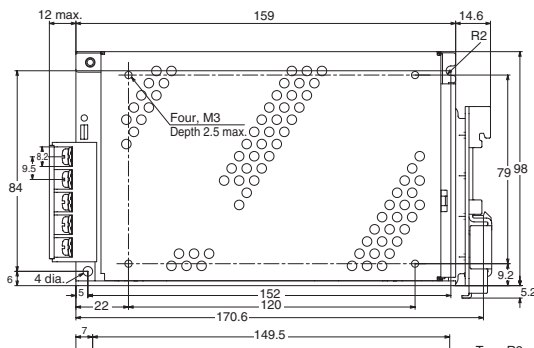

Panel mounting holes dimensions

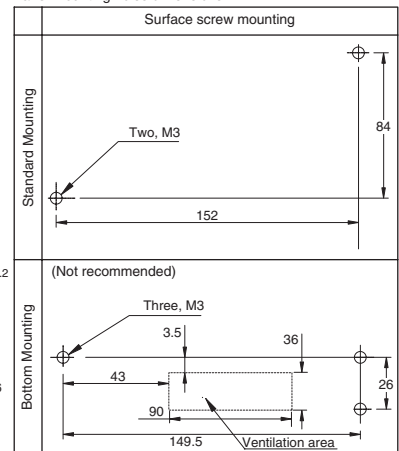

■ DIN Rail (Order Separately)

Note: All units are in millimeters unless otherwise indicated.

Mounting Rail (Material: Aluminum)

PFP-100N
PFP-50N

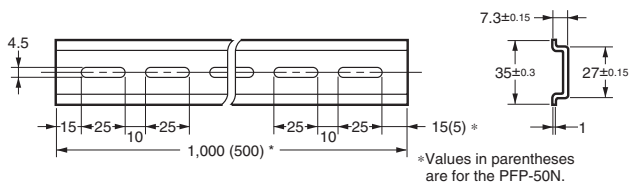
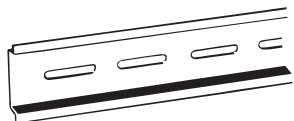





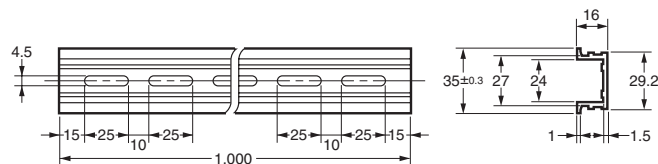

Mounting Rail (Material: Aluminum)

PFP-100N2



Safety Precautions

⚠ CAUTION	
Minor electric shock, fire, or Product failure may occasionally occur. Do not disassemble, modify, or repair the Product to touch the interior of the Product.	
Minor burns may occasionally occur. Do not touch the Product while power is being supplied or immediately after power is turned OFF.	
Fire may occasionally occur. Tighten terminal screws to the specified torque of 0.8 N·m.	
Minor injury due to electric shock may occasionally occur. Do not touch the terminals while power is being supplied. Always close the terminal cover after wiring.	
Minor electric shock, fire, or Product failure may occasionally occur. Do not allow any pieces of metal or conductors or any clippings or cuttings resulting from installation work to enter the Product.	
The residual voltage of up to 373 V generated within the Power Supply may occasionally result in electric shock. Do not touch the internal parts of the Power Supply within 10 seconds after turning OFF the Power Supply.	

■ Precautions for Safe Use

Mounting

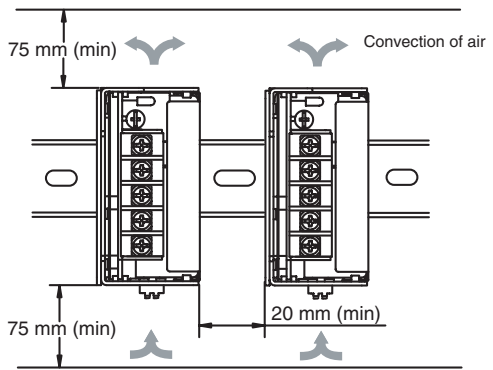

Take adequate measures to ensure proper heat dissipation to increase the long-term reliability of the Product. Be sure to allow convection in the atmosphere around devices when mounting. Do not use in locations where the ambient temperature exceeds the range of the derating curve.

Use the metal plate as the mounting panel.

Improper mounting will interfere with heat dissipation and may occasionally result in deterioration or damage of internal parts. Use the standard mounting method only.

When mounting two or more Power Supplies side-by-side, allow at least 20 mm spacing between them, as shown in the above illustration.

Excessive insertion length may result in damage to the internal parts. Make sure that the insertion length of mounting screws into the Power Supply section does not exceed the specified length indicated in the dimensions diagrams on pages 5 to 6.

When using bottom panel mounting, to ensure good heat dissipation, some openings has to be made. However, it is advisable that the bottom is not covered at all. When using the units' screw hole for mounting, do not tighten the screw more than 2.5 mm from the surface, using 0.54 N·m torque (recommended).

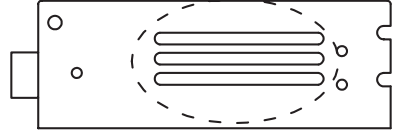

Wiring

Connect the ground completely. A protective earthing terminal stipulated in safety standards is used. Electric shock or malfunction may occur if the ground is not connected completely.

Minor fire may possibly occur. Ensure that input and output terminals are wired correctly.

Do not apply more than 100 N force to the terminal block when tightening it.

Regardless of whether the Unit has a cover or not, before performing machining above the Unit, protect the Unit with a sheet so that the Unit will be free from such metal dust or chips.

Be sure to remove the sheet covering the Product for machining before power-ON so that it does not interfere with heat dissipation.

Use the following material for the wires to be connected to the S8JX to prevent smoking or ignition caused by abnormal loads.

Recommended Wire Type

Model	Recommended wire type
S8JX-03505	AWG 16 to 14 (1.309 to 2.081 mm ²)
S8JX-03512	AWG 18 to 14 (0.823 to 2.081 mm ²)
S8JX-03524	
S8JX-05005	AWG 14 (2.081 mm ²)
S8JX-05012	AWG 18 to 14 (0.823 to 2.081 mm ²)
S8JX-05024	
S8JX-10024	
S8JX-15024	AWG 16 to 14 (1.309 to 2.081 mm ²)

Selection of Wires

Wires for the power supply should must be carefully selected. Refer to this table when selecting the wires.

AWG No.	Cross-sectional area (mm ²)	Configuration (number of conductors/mm)	Voltage drop per 1 A (mV/meter)	Recommended maximum current (A)	
				UL 1007 (300 V at 80°C)	UL 1015 (600 V at 105°C)
30	0.051	7/0.102	358	0.12	---
28	0.081	7/0.127	222	0.15	0.2
26	0.129	7/0.16	140	0.35	0.5
24	0.205	11/0.16	88.9	0.7	1.0
22	0.326	17/0.16	57.5	1.4	2.0
20	0.517	26/0.16	37.6	2.8	4.0
18	0.823	43/0.16	22.8	4.2	6.0
16	1.309	54/0.18	14.9	5.6	8.0
14	2.081	41/0.26	9.5	---	12.0
12	3.309	65/0.26	6.0	---	22.0
10	5.262	104/0.26	3.8	---	35.0

Recommended Maximum Current

The table is applicable to wires with 1 to 4 conductors. Keep the current value to within 80% of the values shown in this table when using wires having 5 or more conductors.

Installation Environment

Do not use the Power Supply in locations subject to shocks or vibrations. In particular, install the Power Supply as far away as possible from contactors or other devices that are a vibration source.

Install the Power Supply well away from any sources of strong, high-frequency noise and surge.

Operating Life

The life of a Power Supply is determined by the life of the electrolytic capacitors used inside. Here, Arrhenius Law applies, i.e., the life will be cut in half for each rise of 10°C or the life will be doubled for each drop of 10°C. The life of the Power Supply can thus be increased by reducing its internal temperature.

Ambient Operating and Storage Environments

Store the Power Supply at a temperature of -25 to 65°C and a humidity of 25% to 90%.

The Internal parts may occasionally deteriorate or be damaged. Do not use the Power Supply outside the derating range (i.e., under conditions indicated by the shaded area (▨) in the derating curve diagram on page 4.)

Use the Power Supply at a humidity of 25% to 85%.

Do not use the Power Supply in locations subject to direct sunlight.

Do not use locations where liquids, foreign matter, or corrosive gases may enter the interior of the Product.

Overcurrent Protection

Internal parts may possibly deteriorate or be damaged if a short-circuited or overcurrent state continues during operation. Remove the cause of the short-circuited or overcurrent state as quickly as possible.

Internal parts may possibly deteriorate or be damaged if the Power Supply is used for applications with frequent inrush current or overloading at the load end. Do not use the Power Supply for such applications.

Dielectric Strength Test

If a high voltage is applied between an input and the case (PE), it will pass through the LC of the built-in noise filter and energy will be stored. If the high voltages used for dielectric strength testing are turned ON and OFF with a switch, timer, or similar device, impulse voltage will be generated when the voltage is turned OFF and internal parts may possibly be damaged. To prevent the generation of impulse voltages, reduce the applied voltage slowly with a variable resistor on the test device or turn the voltage ON and OFF at the zero-cross point.

When performing the test, be sure to short-circuit all the output terminals to protect them from damage.

Insulation Test

When performing the test, be sure to short-circuit all the output terminals to protect them from damage.

Inrush Current

When two or more Power Supplies are connected to the same input, the total current is the sum of the currents for each Supply. Select fuses and circuit breakers giving sufficient consideration to the fusing or operating characteristics so that fuses will not burn and breakers will not break due to inrush current.

Output Voltage Adjuster (V.ADJ)

The output voltage adjuster (V.ADJ) is set to the rated voltage as the factory setting.

Adjustment range: The rated voltage can be adjusted using the output voltage adjuster (V.ADJ) on the front panel to between -10% to 15%. Turning to the right will raise the output voltage and turning to the left will lower the output voltage.

The output voltage adjuster (V.ADJ) may possibly be damaged if it is turned with unnecessary force. Do not turn the adjuster with excessive force.

After completing output voltage adjustment, be sure that the output capacity or output current does not exceed the rated output capacity or rated output current.

The output voltage may increase above the adjustable voltage range (rated voltage +15%) depending on the operation of the output voltage adjuster (V.ADJ). When adjusting the output voltage, make sure that the Power Supply output voltage will not damage the load.

DIN Rail Mounting

To mount the Power Supply on a DIN rail, hook portion (A) of the Power Supply onto the rail and press the Power Supply in direction (B).

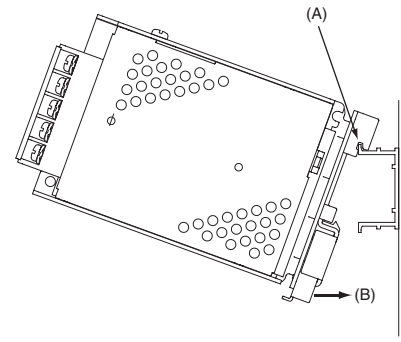

To dismount the Power Supply, pull down portion (C) with a flat-blade screwdriver and pull out the Power Supply.

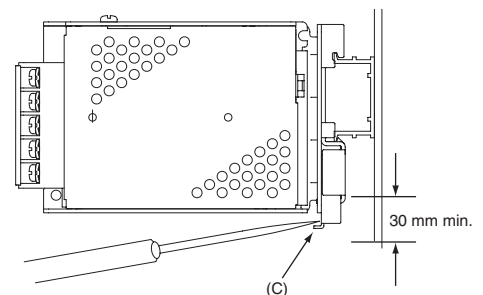

Series Operation

The Product is not designed for series operation.

Incorrect

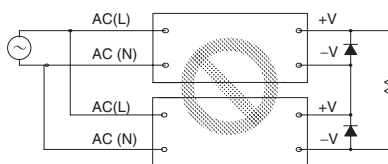

Parallel Operation

The Product is not designed for parallel operation.

Incorrect

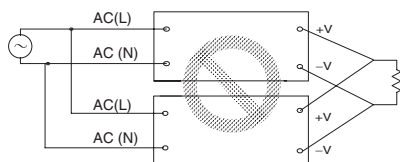

In Case There Is No Output Voltage

The possible cause for no output voltage may be that the overcurrent has operated. The internal protection may operate if a large amount of surge voltage such as a lightning surge occurs while turning ON the Power Supply.

In case there is no output voltage, please check the following points before contacting us:

- Checking overload protected status:
Check whether the load is in overload status or is short-circuited.
Remove wires to load when checking.
- Check whether the supply input voltage is within the input range, or the ventilation is sufficient. Before checking, shut off power for 30 mins.

Warranty and Application Considerations

Read and Understand this Catalog

Please read and understand this catalog before purchasing the products. Please consult your OMRON representative if you have any questions or comments.

Warranty and Limitations of Liability

WARRANTY

OMRON's exclusive warranty is that the products are free from defects in materials and workmanship for a period of one year (or other period if specified) from date of sale by OMRON.

OMRON MAKES NO WARRANTY OR REPRESENTATION, EXPRESS OR IMPLIED, REGARDING NON-INFRINGEMENT, MERCHANTABILITY, OR FITNESS FOR PARTICULAR PURPOSE OF THE PRODUCTS. ANY BUYER OR USER ACKNOWLEDGES THAT THE BUYER OR USER ALONE HAS DETERMINED THAT THE PRODUCTS WILL SUITABLY MEET THE REQUIREMENTS OF THEIR INTENDED USE. OMRON DISCLAIMS ALL OTHER WARRANTIES, EXPRESS OR IMPLIED.

LIMITATIONS OF LIABILITY

OMRON SHALL NOT BE RESPONSIBLE FOR SPECIAL, INDIRECT, OR CONSEQUENTIAL DAMAGES, LOSS OF PROFITS, OR COMMERCIAL LOSS IN ANY WAY CONNECTED WITH THE PRODUCTS, WHETHER SUCH CLAIM IS BASED ON CONTRACT, WARRANTY, NEGLIGENCE, OR STRICT LIABILITY.

In no event shall the responsibility of OMRON for any act exceed the individual price of the product on which liability is asserted.

IN NO EVENT SHALL OMRON BE RESPONSIBLE FOR WARRANTY, REPAIR, OR OTHER CLAIMS REGARDING THE PRODUCTS UNLESS OMRON'S ANALYSIS CONFIRMS THAT THE PRODUCTS WERE PROPERLY HANDLED, STORED, INSTALLED, AND MAINTAINED AND NOT SUBJECT TO CONTAMINATION, ABUSE, MISUSE, OR INAPPROPRIATE MODIFICATION OR REPAIR.

Application Considerations

SUITABILITY FOR USE

OMRON shall not be responsible for conformity with any standards, codes, or regulations that apply to the combination of products in the customer's application or use of the products.

Take all necessary steps to determine the suitability of the product for the systems, machines, and equipment with which it will be used.

Know and observe all prohibitions of use applicable to this product.

NEVER USE THE PRODUCTS FOR AN APPLICATION INVOLVING SERIOUS RISK TO LIFE OR PROPERTY WITHOUT ENSURING THAT THE SYSTEM AS A WHOLE HAS BEEN DESIGNED TO ADDRESS THE RISKS, AND THAT THE OMRON PRODUCTS ARE PROPERLY RATED AND INSTALLED FOR THE INTENDED USE WITHIN THE OVERALL EQUIPMENT OR SYSTEM.

Disclaimers

PERFORMANCE DATA

Performance data given in this catalog is provided as a guide for the user in determining suitability and does not constitute a warranty. It may represent the result of OMRON's test conditions, and the users must correlate it to actual application requirements. Actual performance is subject to the OMRON *Warranty and Limitations of Liability*.

CHANGE IN SPECIFICATIONS

Product specifications and accessories may be changed at any time based on improvements and other reasons. Consult with your OMRON representative at any time to confirm actual specifications of purchased product.

DIMENSIONS AND WEIGHTS

Dimensions and weights are nominal and are not to be used for manufacturing purposes, even when tolerances are shown.